



PROCESS MACHINERY



Fluorescent Penetrant Inspection (FPI) Manual Systems



**MADE IN
THE USA**

relinc.com



Fluorescent Penetrant Inspection (FPI) System, Model I2C features:

- 3 Standard sizes available with 3 months (or less) Lead Time
- Configurations for Method A & Method D processing
- Configurations for Form A, B, and D Developers
- Shape configurations - Straight Line, L, and U
- Can be deployed anywhere in the world
- Built-in surrounds and station transfer flashings keep effluents contained in the stations
- Ergonomic roller height of 36" from the floor
- Minimal facility connections
- Complete Operations and Maintenance Manual and Installation Instructions included



**MADE IN
THE USA**

relinc.com

COMMON CONFIGURATIONS

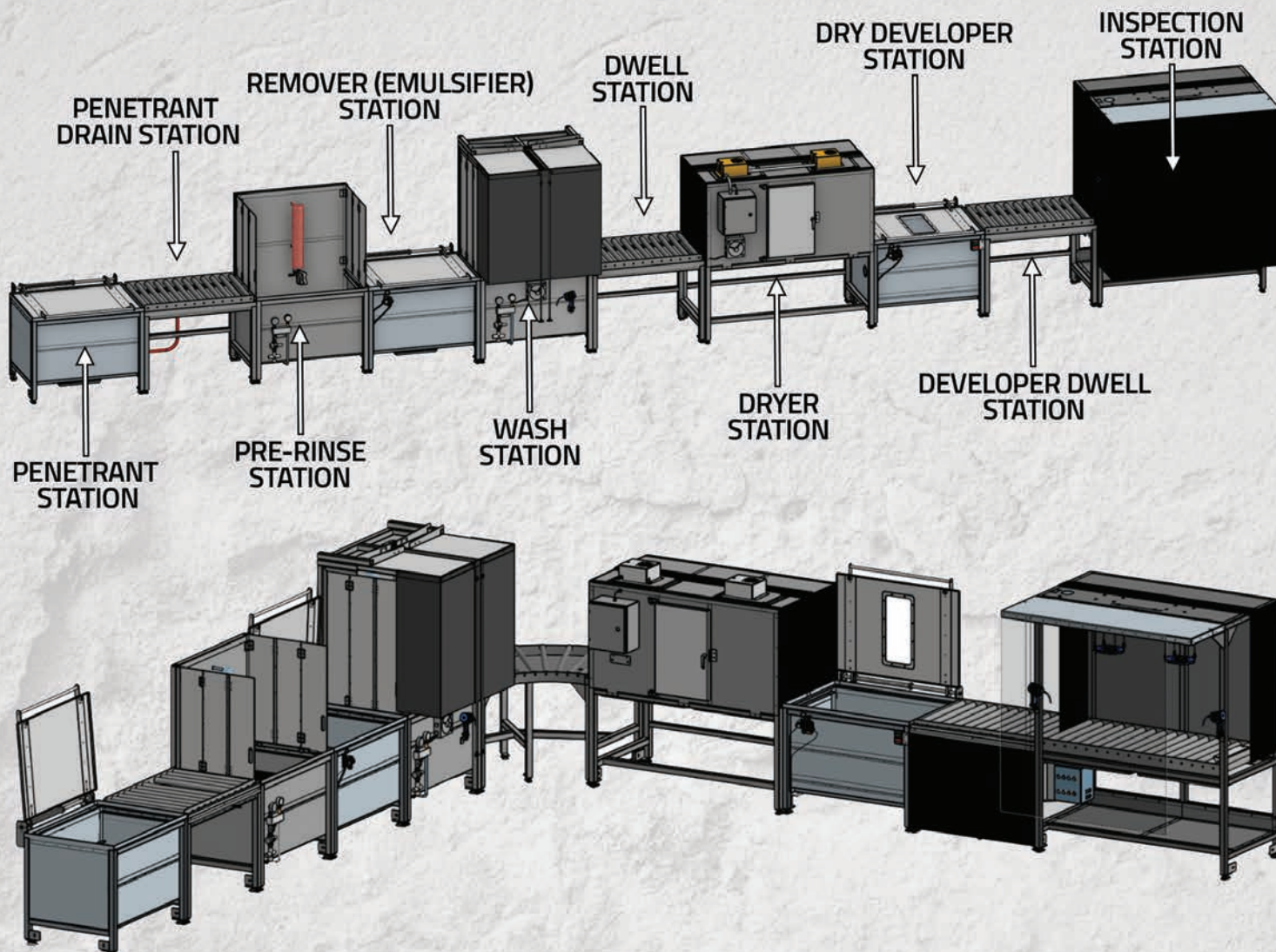

STANDARD PART ENVELOPES*

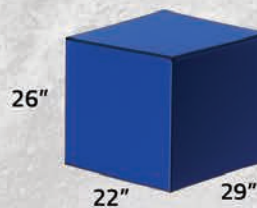
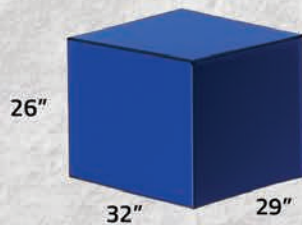
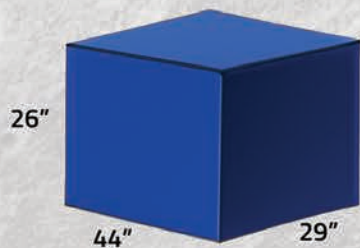

* Custom engineered station sizes available

MILITARY CONFIGURATIONS OPTIONS

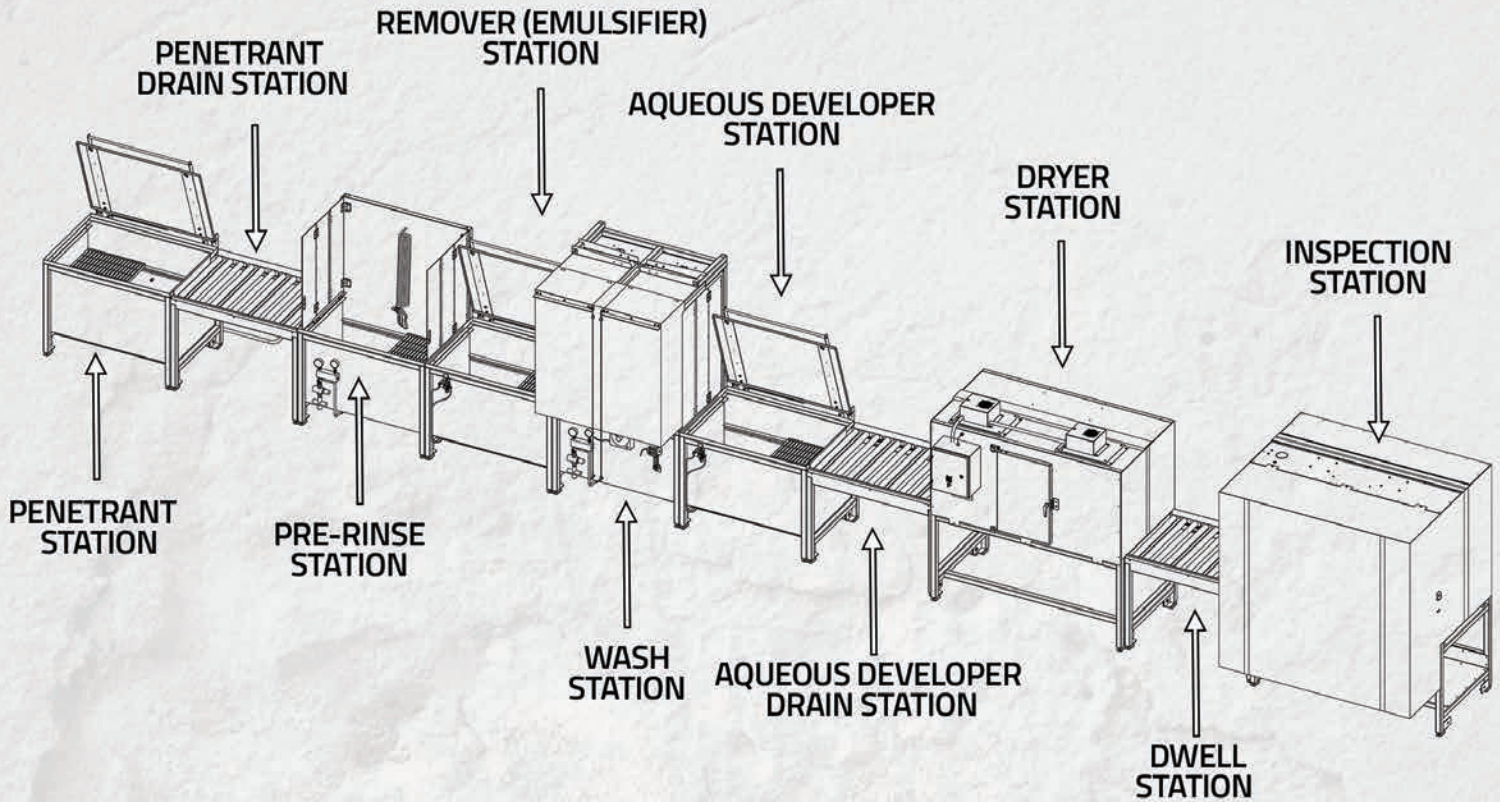

- **SIZE 2 METHOD D - AQUEOUS DEVELOPER**
with NSN # 6635-01-689-6585
- **SIZE 3 METHOD D - AQUEOUS DEVELOPER**
with NSN # 6635-01-689-6583
- **SIZE 5 METHOD D - AQUEOUS DEVELOPER**
with NSN # 6635-01-689-6016

SYSTEM OPTIONS

LOWERATOR

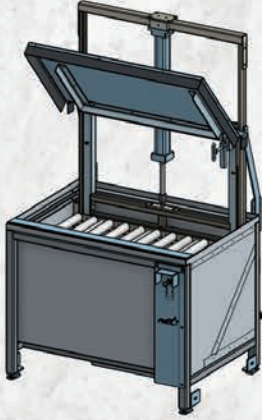

PENETRANT SPRAY & MIST COLLECTOR

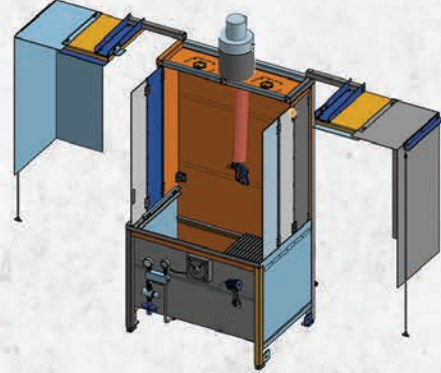

CORNER TURN

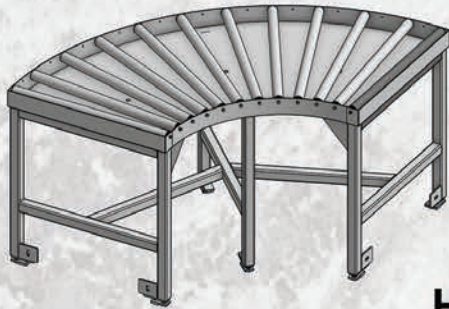

WATER TREATMENT

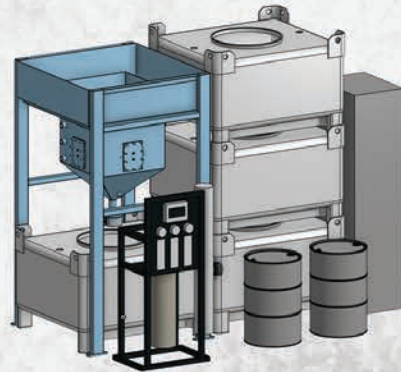

HEPA VACUUM



BASKET/TRAYS

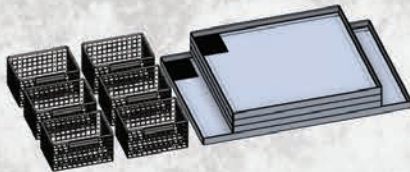

TORIT DUST COLLECTOR



OVERHEAD CRANE

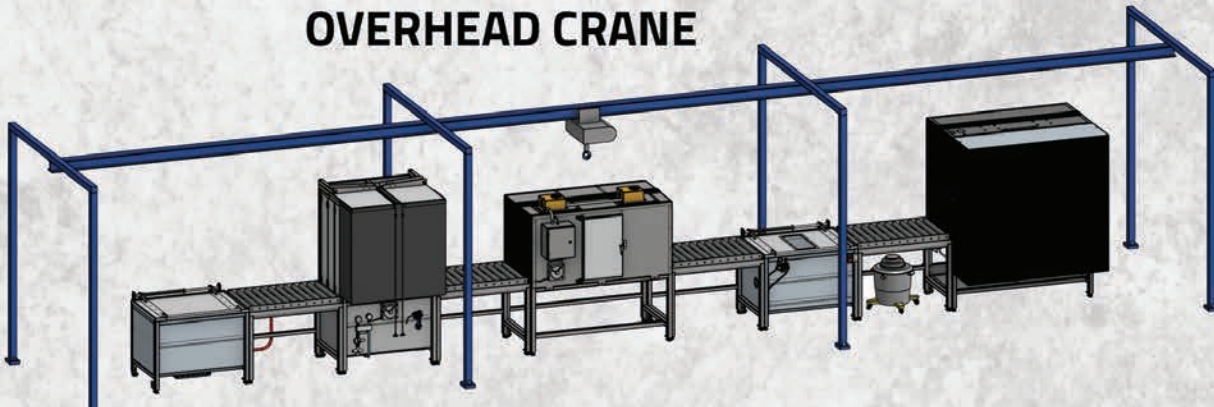

MODULAR SYSTEM STATIONS

■ PENETRANT

■ PENETRANT DRAIN

■ PRE-RINSE

■ REMOVER

■ WASH

REST

■ DRYER

■ DRY DEVELOPER

■ REST

■ INSPECTION

AQUEOUS DEVELOPER

AQUEOUS DEVELOPER DRAIN

■ LOWERATOR

■ CORNER TURN

■ SELECTED STATIONS

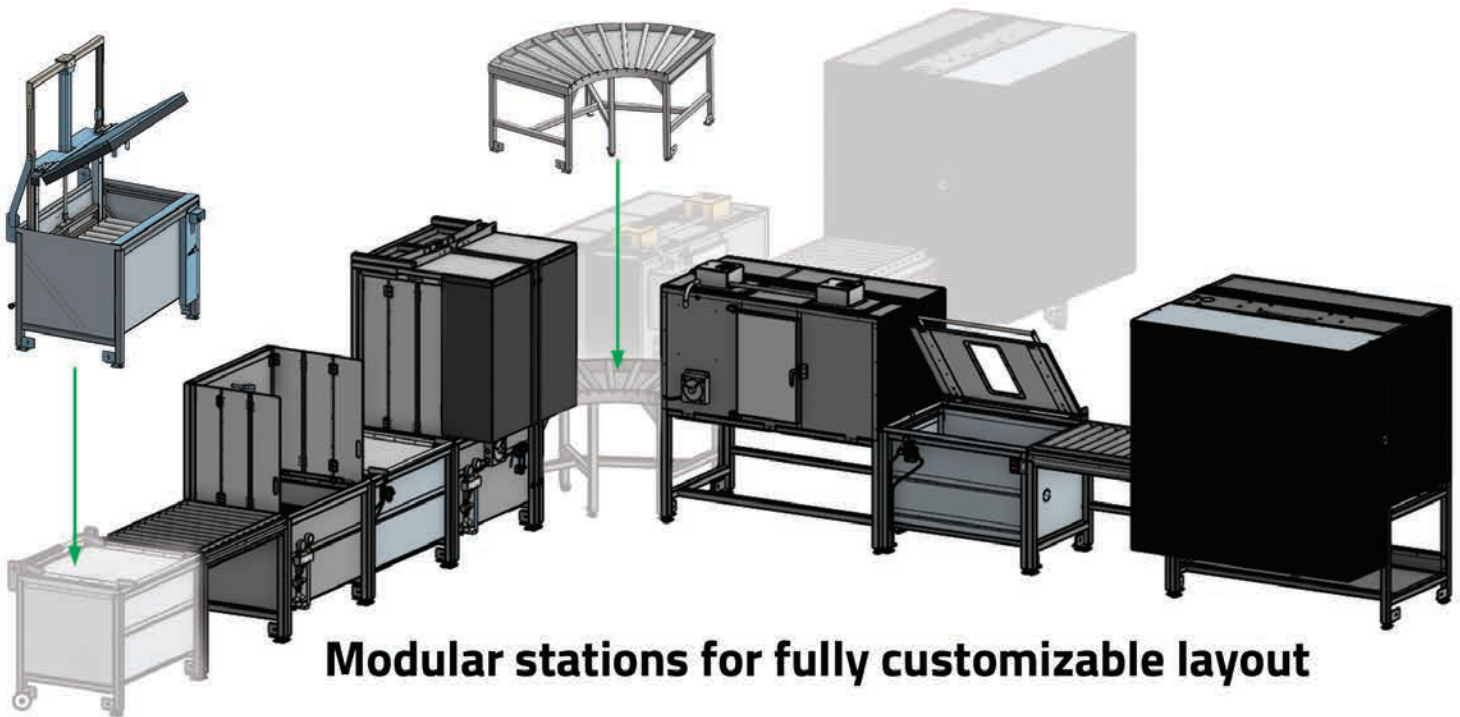

TURNKEY SYSTEM

PROCESS TOOLS INCLUDED

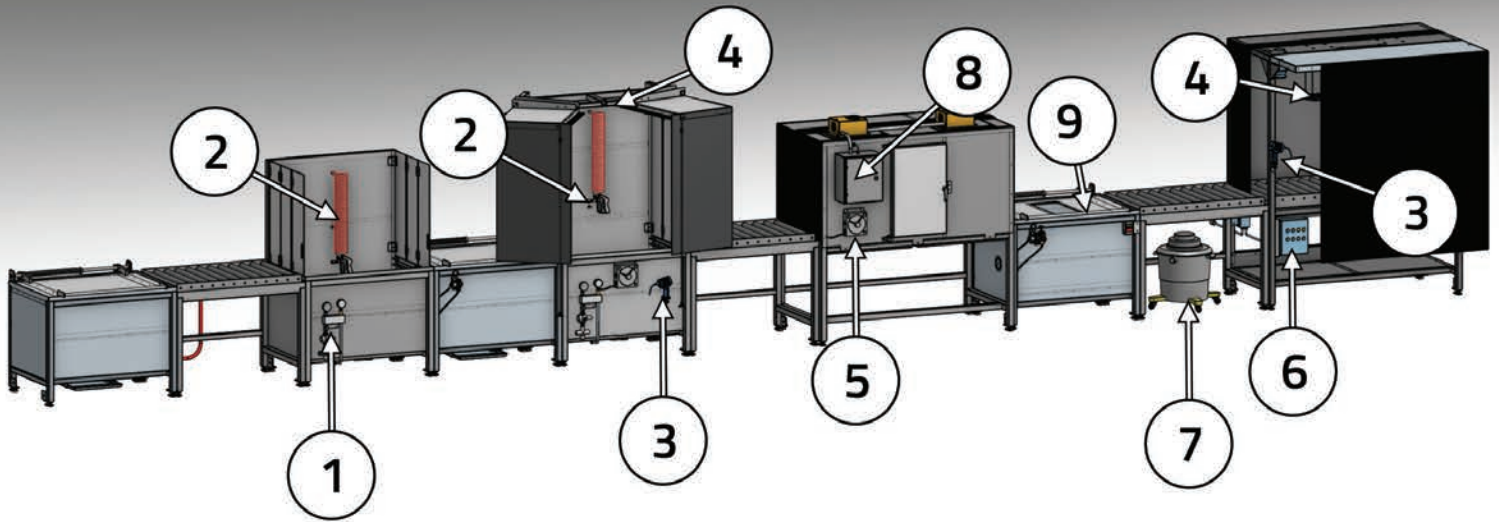

1. CERTIFIED GAUGES -
TEMPERATURE & PRESSURE
2. SPRAY GUNS & HOSES
3. C4 MAGNUM LED UV-A LAMP (QTY 3) UV-2000
NSN# 5980-01-671-7903
4. PROFUSION LED UV-A LAMP (QTY 4) UV-4000

5. GRALAB TIMER
6. STATION CONTROL PANEL
7. HEPA VACUUM DUST CONTROL
8. CERTIFIED DRYER CONTROL PANEL
9. PROFUSION CASPER WHITE LIGHT (UV-4000W)

UTILITIES

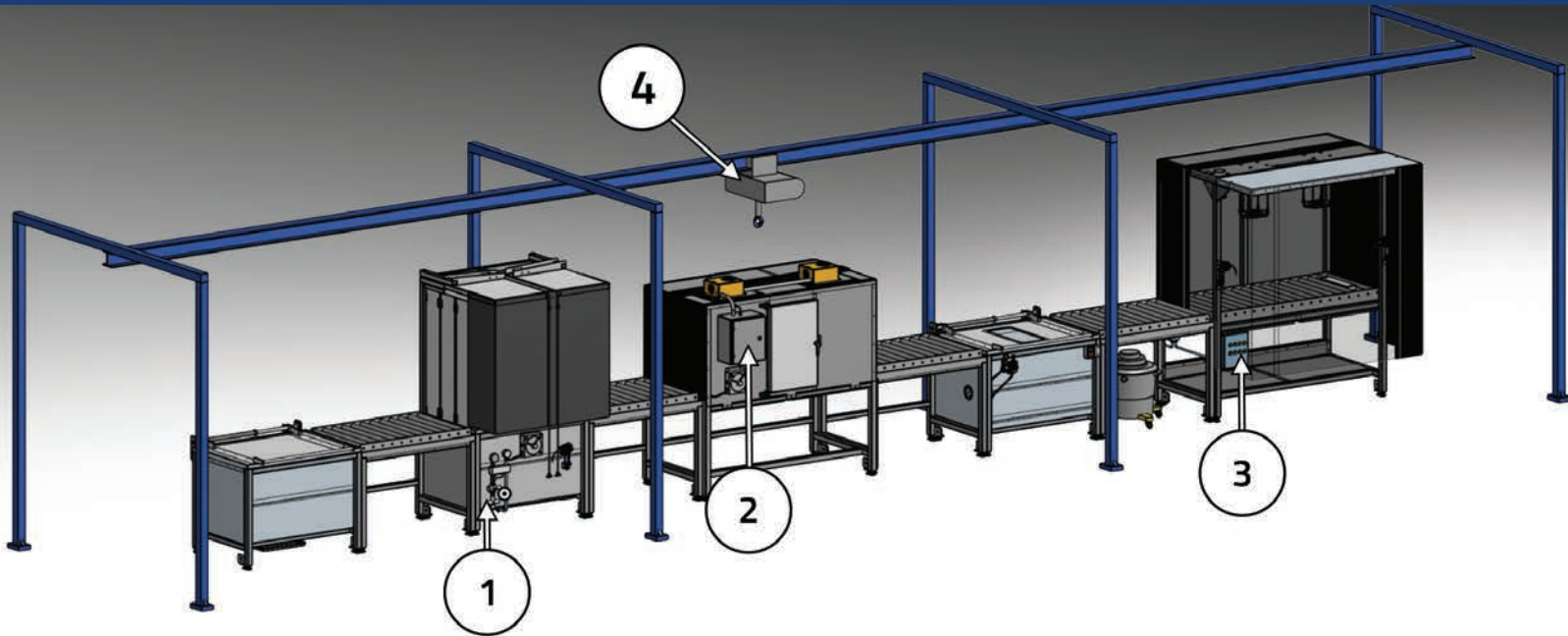

**1. HOT/COLD WATER SUPPLY
MINIMUM REQUIREMENTS**
- FLOW: 10 GPM
- PRESSURE: 60 PSI

2. DRYER ELECTRICAL PANEL
208-240V, 1-PH, 60A SUPPLY

3. ELECTRICAL PANEL
20 AMP, 2.4 kW

**4. OVERHEAD MONORAIL CRANE
WITH 500 LB. CAPACITY HOIST**
120V, 1PH, 20A

5. AIR SUPPLY IN
1/4" IND. QUICK DISCONNECT
MINIMUM REQUIREMENTS
- FLOW: 5 CFM
- PRESSURE: 60 PSI

6. DRAIN
3/4" NPT

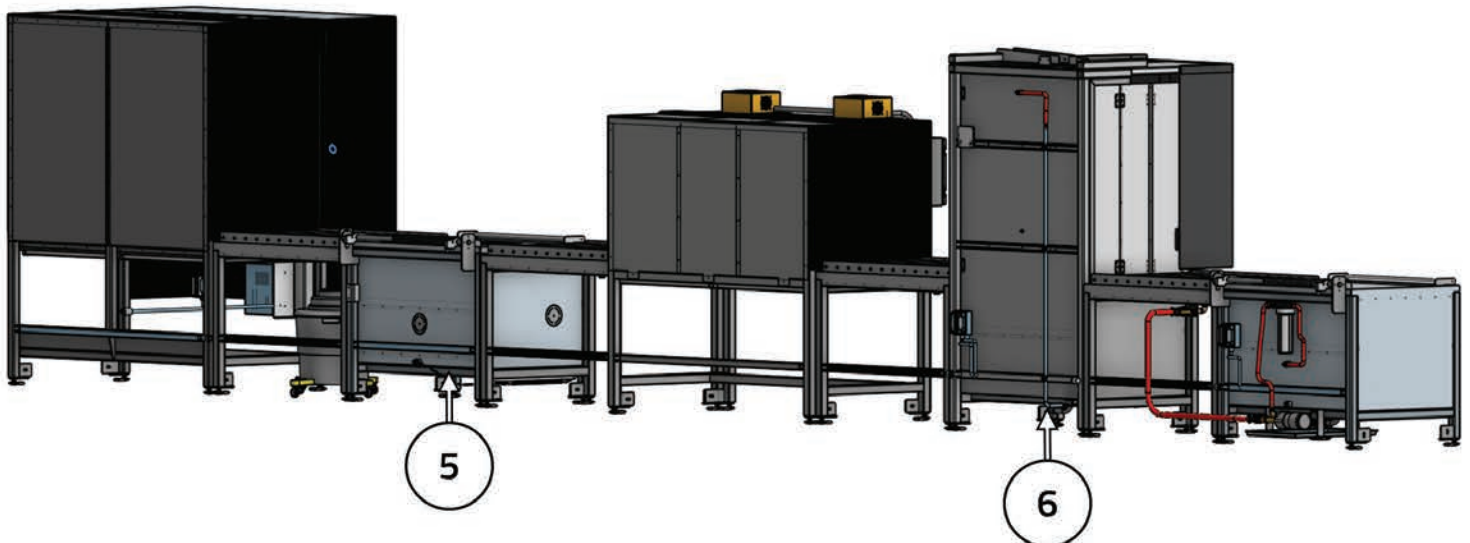

STANDARD FEATURES

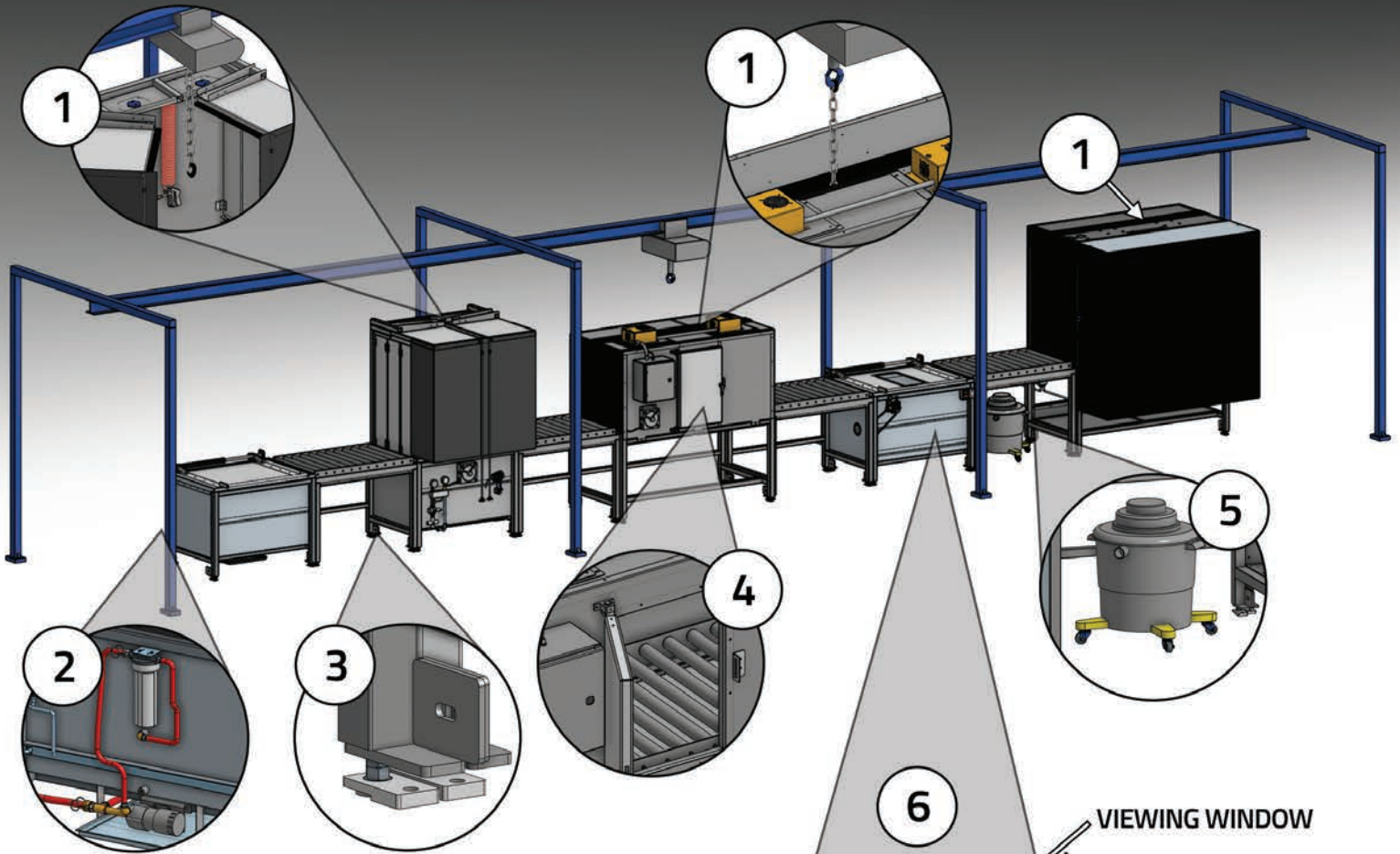

- 1. OVERHEAD CRANE ACCESS
- 2. INTEGRAL PENETRANT DISCHARGE
1/2" x 12' CAMLOCK FITTING HOSE
- 3. STATION BOLT TOGETHER / BOLT TO FLOOR
- 4. DRYER DOOR ACCESS
- 5. HEPA VACUUM
- 6. DRY DEVELOPER

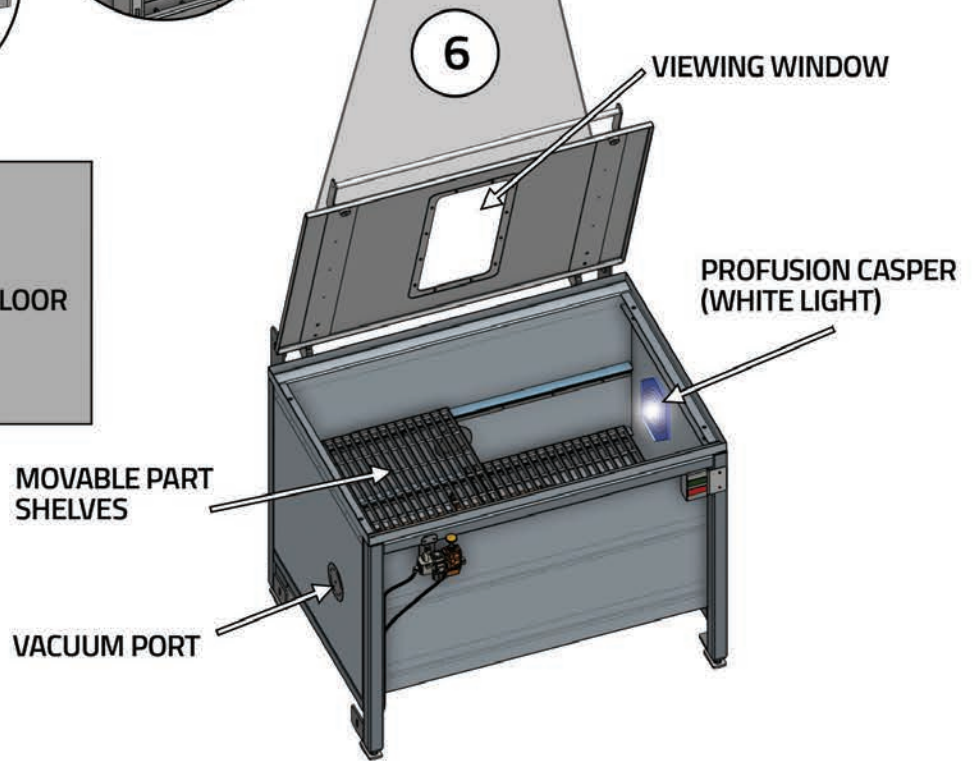

OPTIONAL FEATURES

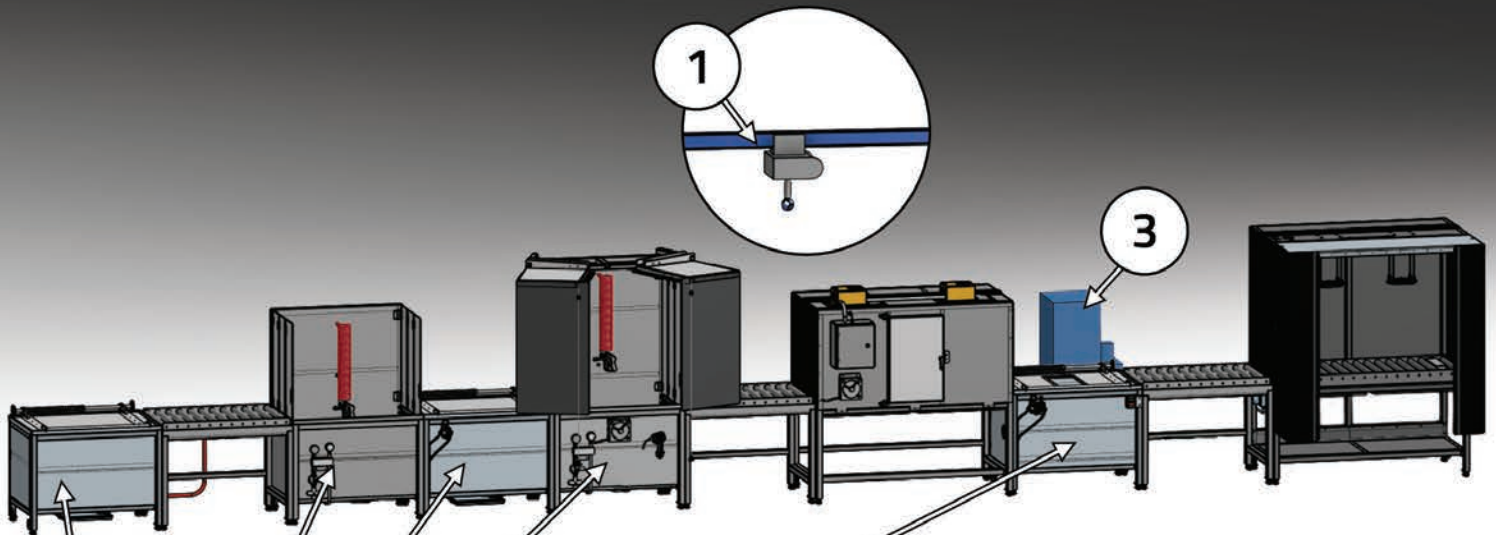

- 1. OVERHEAD CRANE
- 2. PNEUMATIC LOWERATOR
- 3. TORIT DUST COLLECTION

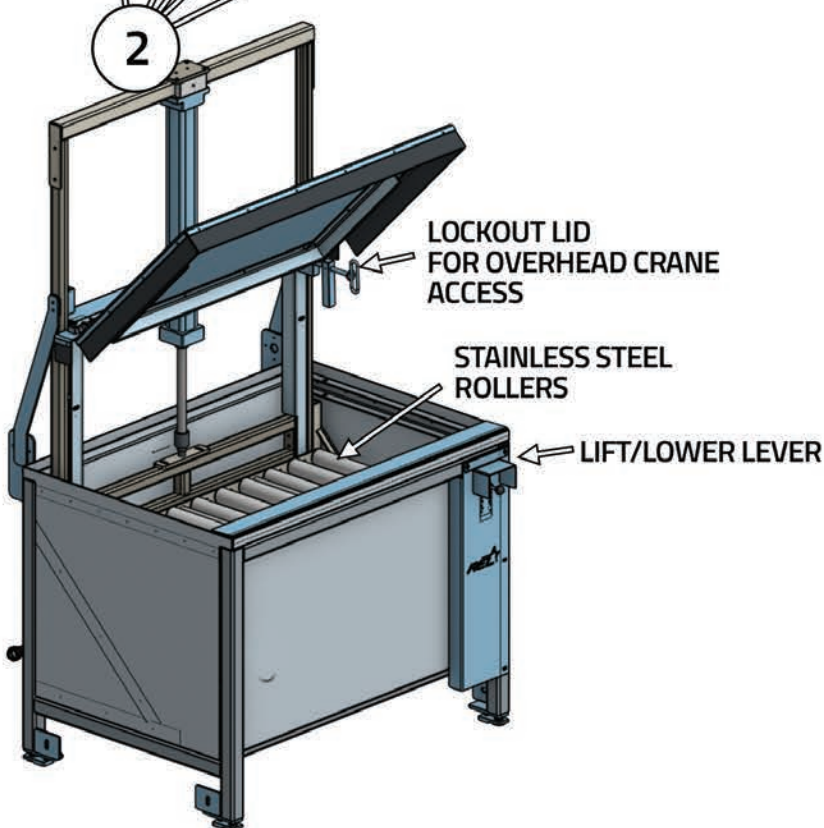

PNEUMATIC LOWERATOR

CAN BE ADDED TO ANY TANK STATION
(WASH, EMULSIFIER, ETC.)

STATION ATTRIBUTES

Penetrant Station

Design Characteristics

- 304ss 2X2 Structural Tube Frame
- Heavy Duty 14 gauge Stainless Steel Tank construction
- Heavy Duty 14 gauge Stainless Steel Basket and Shelf Brackets (3 levels)
- 2 Adjustable Military Grade Aluminum Split Shelves
- Torsion spring counterbalanced 10 gauge Military Grade Aluminum tank Lid with soft close cushions
- 1/2-13 ss leveling feet with integrated anchoring pad
- Adjacent Station bolted connection for station fastness
- Forklift locations under tank for ease of installation/moving

Design Features

- Sloped Bottom Tank to Center Drain with Integral Welded 3/4 NPT 3-piece Ball valve to eliminate Leaks
- Integrated Filter with quick connect Fittings to Circulation Pump
- Circulation Pump with Cam lock fitting and 10' hose for Penetrant Changeout
- Removable/integrated pump connection drip pan
- Large part envelope
- 36" operator working height
- Overhead crane accessible
- Station outlet for Pump Control
- *Optional* Pneumatic Lowerator with 1.9" Stainless Steel Rollers 4" O.C.
- *Optional* Curtains and Aluminum Surround for Penetrant Spray Application

Station Function

The station is designed to process parts using the penetrant dip (or optional spray) application method. The parts are immersed (or sprayed) with penetrant then set aside on the dwell station for a pre-determined dwell time. A mist collector with a HEPA filter is included if the spray option is quoted. A GRALab Timer is available to be set on the system. Penetrant coverage can be verified with included system ASTM E3022 Certified handheld LED UV-A Lamps.

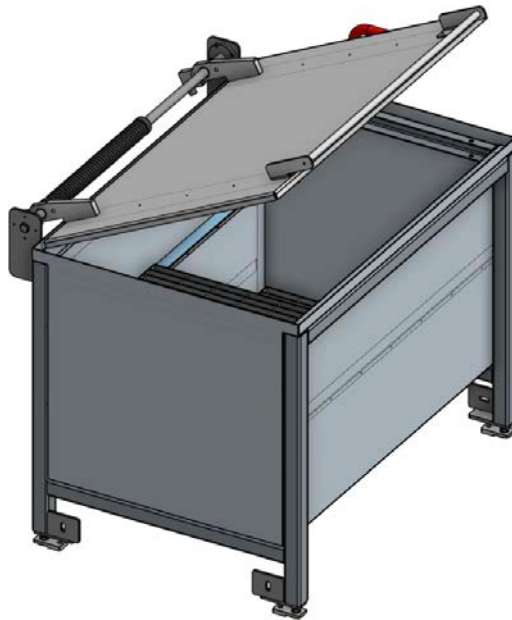

STATION ATTRIBUTES

Penetrant Drain / Dwell Station

Design Characteristics

- 304ss 2X2 Structural Tube Frame
- Heavy Duty 14 gauge Stainless Steel Drip Pan construction
- Heavy Duty 1.9" Stainless Steel Conveyor Rollers 4" O.C.
- 1/2-13 ss leveling feet with integrated anchoring pad
- Adjacent Station bolted connection for station positioning fastness
- Forklift locations under pan for ease of installation/moving

Design Features

- Sloped Bottom Tank to Center Drain with Integral Welded 3/4 NPT 3-piece Ball valve to eliminate Leaks
- Camlock fittings back to penetrant station pump inlet to filter penetrant before going back into tank
- Large part envelope
- 36" operator working height
- Polymer Drip caps between adjacent stations
- Overhead crane accessible

Station Function

Parts are placed on this station for a recipe driven dwell time. A GRALab Timer is available to be set on the system. Penetrant coverage can be verified with included system ASTM E3022 Certified handheld LED UV-A Lamps.



STATION ATTRIBUTES

Pre-Rinse Station

Design Characteristics

- 304ss 2X2 Structural Tube Frame
- Heavy Duty 14 gauge Stainless Steel Tank construction
- Heavy Duty 14 gauge Stainless Steel Basket and Shelf Brackets (3 levels)
- 2 Adjustable Military Grade Aluminum Split Shelves
- 1/2-13 ss leveling feet with integrated anchoring pad
- Adjacent Station bolted connection for station fastness
- Forklift locations under tank for ease of installation/moving

Design Features

- Sloped Bottom Tank to Center Drain with Integral Welded 3/4 NPT 3-piece Ball valve to eliminate Leaks
- Large part envelope
- 36" operator working height
- Overhead crane accessible
- *Optional* Pneumatic Lowerator with 1.9" Stainless Steel Rollers 4" O.C.
- Military grade Aluminum tri-fold end doors with flip lock for rinsing
- Station mounted pressure reducing valve
- Station mounted Water Temperature Regulating Valve
- Wash gun assembly for 4-finger ergonomic control
- Polymer Drip caps between adjacent stations
- NIST Traceable Pressure Gage Supplied with System, mounted on a quick disconnect coupling
- NIST Traceable Temperature Gage Supplied with System, mounted in thermowell

Station Function

The station is designed to process parts through a contained manual spray wash. The timing of the wash cycle should be established through industry best practice. A GRALab Timer is available to be set on the system. Part rinse be verified with included system ASTM E3022 Certified handheld LED UV-A Lamps.

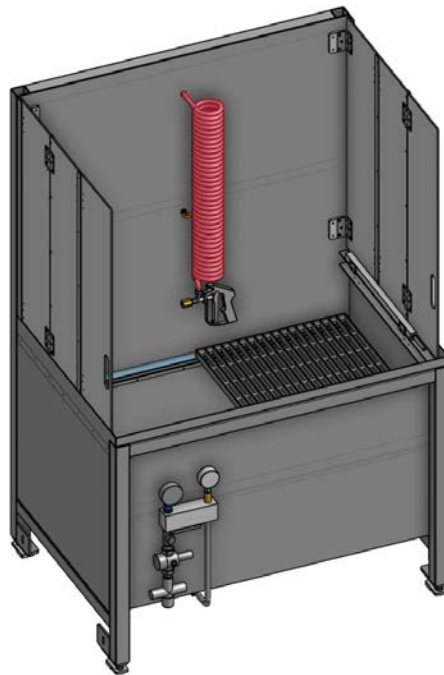

STATION ATTRIBUTES

Remover (Emulsifier) Station

Design Characteristics

- 304ss 2X2 Structural Tube Frame
- Heavy Duty 14 gauge Stainless Steel Tank construction
- Heavy Duty 14 gauge Stainless Steel Basket and Shelf Brackets (3 levels)
- 2 Adjustable Military Grade Aluminum Split Shelves
- Torsion spring counterbalanced 10 gage Military Grade Aluminum tank Lid with soft close cushions
- 1/2-13 ss leveling feet with integrated anchoring pad
- Adjacent Station bolted connection for station fastness
- Forklift locations under tank for ease of installation/moving

Design Features

- Sloped Bottom Tank to Center Drain with Integral Welded 3/4 NPT 3-piece Ball valve to eliminate Leaks
- Integrated Filter with quick connect Fittings to Circulation Pump
- Circulation Pump with Cam lock fitting and 10' hose for Remover Changeout
- Removable/integrated pump connection drip pan
- Large part envelope
- 36" operator working height
- Overhead crane accessible
- Station outlet for Pump Control
- *Optional* Pneumatic Lowerator with 1.9" Stainless Steel Rollers 4" O.C.
- Air valve with safety lockout
- Air agitation sparge
- Drip pan
- Circulation hose

Station Function

The station is designed to process parts through penetrant emulsification. The timing of the remover cycle should be established through industry best practice. A GRALab Timer is available to be set on the system. Attention to post wash timing after emulsification should be in accordance with ASTM E1417 which allows for a maximum exposure to remover of 2 minutes before part surfaces must be rinsed. Part surface emulsification can be verified with included system ASTM E3022 Certified handheld LED UV-A Lamps.



STATION ATTRIBUTES

Wash Station

Design Characteristics

- 304ss 2X2 Structural Tube Frame
- Heavy Duty 14 gauge Stainless Steel Tank construction
- Heavy Duty 14 gauge Stainless Steel Basket and Shelf Brackets (3 levels)
- 2 Adjustable Military Grade Aluminum Split Shelves
- 1/2-13 ss leveling feet with integrated anchoring pad
- Adjacent Station bolted connection for station fastness
- Forklift locations under tank for ease of installation/moving

Design Features

- Sloped Bottom Tank to Center Drain with Integral Welded 3/4 NPT 3-piece Ball valve to eliminate Leaks
- Large part envelope
- 36" operator working height
- Overhead crane accessible with station rotating curtain assemblies
- Complete with flame resistant split curtains at the entrance and exit portal that meet MIL-PRF-20696F, Type II, Class 2
- *Optional* Pneumatic Lowerator with 1.9" Stainless Steel Rollers 4" O.C.
- Military grade Aluminum tri-fold end doors with flip lock for rinsing
- Station mounted pressure reducing valve
- Station mounted Water Temperature Regulating Valve
- Wash gun assembly for 4-finger ergonomic control
- Polymer Drip caps between adjacent stations
- NIST Traceable Pressure Gage Supplied with System mounted on a quick disconnect coupling
- NIST Traceable Temperature Gage Supplied with System mounted in thermowell
- Station is pre-wired and includes two (2) Overhead UV-4000 Profusion LED UV-A Lamps
- Station is pre-wired and includes one (1) handheld UV-2000 C4 Magnum LED UV-A Lamp
- Qty 1 GRALAB Model 300 Timer

Station Function

The station is designed to process parts through a contained manual post spray wash. The timing of the wash cycle should be established through industry best practice. A GRALab Timer is available to be set on the system. Part rinse be verified with included system ASTM E3022 Certified handheld LED UV-A Lamps.

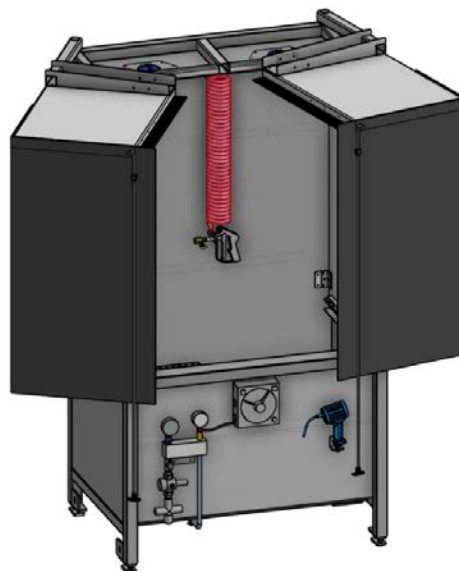

STATION ATTRIBUTES

Dryer Station

Design Characteristics

- Epoxy painted 2X2 high strength Structural Steel Tube Frame
- Heavy Duty 14 gauge Cold Rolled Steel Tank construction
- Front operator access door (size 5 and bigger dryers)
- Heavy Duty 14 gauge galvanized reflective inside dryer skin for corrosion resistance and energy efficiency
- 1/2-13 ss leveling feet with integrated anchoring pad
- Adjacent Station bolted connection for station positioning fastness
- Heavy Duty 1.9" Galvanized High Temperature Conveyor Rollers 4" O.C.
- Forklift locations under tank for ease of installation/moving

Design Features

- Large part envelope
- 36" operator working height
- Overhead crane accessible
- Complete with flame resistant split curtains at the entrance and exit portals that meet MIL-PRF-20696F, Type II, Class 2
- 1 Removable Top Curtain (for crane access) with same spec as above
- 2 Removable under Roller Dust Pans
- Temperature control on/off switch
- Safety Lockout
- Heat up time = 10 min w/temperature variance of less than +/-10 degree Fahrenheit with curtains closed.
- Electrical power of 250 Watts per cubic foot of Dryer volume
- NIST Traceable RTD and Digital Temp Controller with maximum setpoint of 160 degrees Fahrenheit
- Temperature Calibration port included on the outside of the electrical enclosure for easy access for periodic calibrations
- Overhead crane accessible

Station Function

The station is designed to dry parts with out exceeding recipe constraints of time and temperature variability outside of the maximum specified in ASTM E1417. The parts can be conveyed on the rollers into the dryer through the end curtains for a settable time. A GRALab timer is available to be set on the system.



STATION ATTRIBUTES

Dry Developer Station

Design Characteristics

- 304ss 2X2 Structural Tube Frame
- Heavy Duty 14 gauge Stainless Steel Tank construction
- Heavy Duty 14 gauge Stainless Steel Basket and Shelf Brackets (3 levels)
- 2 Adjustable Military Grade Aluminum Split Shelves
- Torsion spring counterbalanced 10 gage Military Grade Aluminum tank Lid with soft close cushions
- 1/2-13 ss leveling feet with integrated anchoring pad
- Adjacent Station bolted connection for station positioning fastness
- Forklift locations under tank for ease of installation/moving

Design Features

- Large part envelope
- 36" operator working height
- Overhead crane accessible
- Station outlet for HEPA Vacuum Dust Control
- Air Agitation System for dynamic developer dust application
- 8ft Air Hose for manual blow off regulated to 5 psi
- Push-Button Air Valve actuator with safety lockout
- *Optional* Pneumatic Lowerator with 1.9" Stainless Steel Rollers 4" O.C.
- *Optional* Curtains and Aluminum Surround for Developer Spray/Flocking Application

Station Function

The station is designed to process parts using air to accelerate developer powder to the surface of dried part with the dynamic cloud (Or optional spray) application method. The parts are immersed (or sprayed) in a cloud of developer particulate that is accelerated with air in the station. A GRALab timer is available to be set on the system. Station Developer quality can be verified with the REL DTA-1000 at the required periodicity.

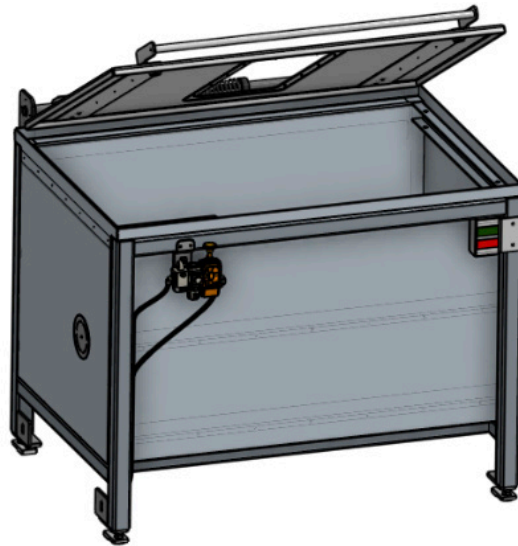

STATION ATTRIBUTES

Inspection Station

Design Characteristics

- Black Epoxy painted 2X2 high strength Structural Steel Tube Frame
- Heavy Duty 14 gauge Cold Rolled Steel station panel construction
- Heavy Duty 14 gauge Debris pans that slide out under rollers
- 1/2-13 ss leveling feet with integrated anchoring pad
- Adjacent Station bolted connection for station positioning fastness
- Heavy Duty 1.9" Galvanized High Temperature Conveyor Rollers 4" O.C.
- Bottom Storage Shelf
- Forklift locations under tank for ease of installation/moving

Design Features

- Large part envelope
- Curtained Environment with less than 2 FC of white light at the part inspection surface
- 36" operator working height
- Overhead crane accessible
- Complete with flame resistant split curtains at the entrance and exit portals that meet MIL-PRF-20696F, Type II, Class 2
- 1 Removable Top Curtain (for crane access) with same spec as above
- Temperature control on/off switch
- 20 Amp, 120V panel for system lighting, pumps, and fans with safety lockout
- Safety Lockout
- 2 Overhead UV-4000 Profusion LED UV-A Blacklights
- 2 UV-2000 C4 Magnum LED UV-A Handheld Blacklights
- Overhead White Light
- 100 CFM Booth Ventilation Fan
- Conveyor insert for Basket runaway control
- Overhead crane accessible

Station Function

The station is designed to inspect processed parts in a controlled ergonomically designed work center. This station includes all process tools necessary and meets the requirements of ASTM E1417 to perform inspections, including background LED UV-A lamps and handheld inspection lamps that meet ASTM E3022.

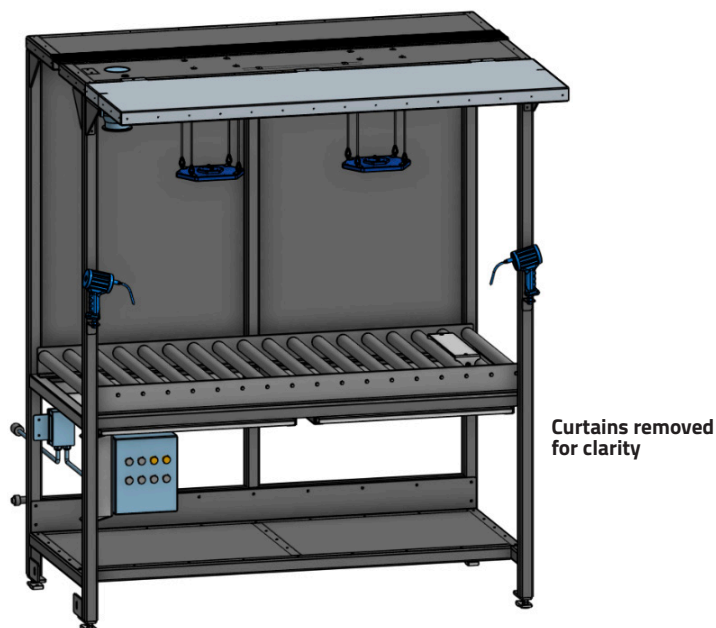



25 Year Resume

> 100 FPI Lines for Industry

Designed
Engineered
Manufactured
Installed
Supported

Proven Products

LED UV-A Lamps (>10,000 in service)
Safety Critical NDT Processing Equipment
Safety Critical Metal Etch Processing Equipment
Safety Critical Control Solutions

Partners of Industry

Military
Aerospace
Energy
Automation



Made in
US of eh!

relinc.com



PROCESS MACHINERY

Fluorescent Penetrant Inspection System Model I2C



relinc.com